

EN

INSTALLATION AND USE INSTRUCTIONS

CHAIN ACTUATOR FOR
WINDOW AUTOMATION

C40S

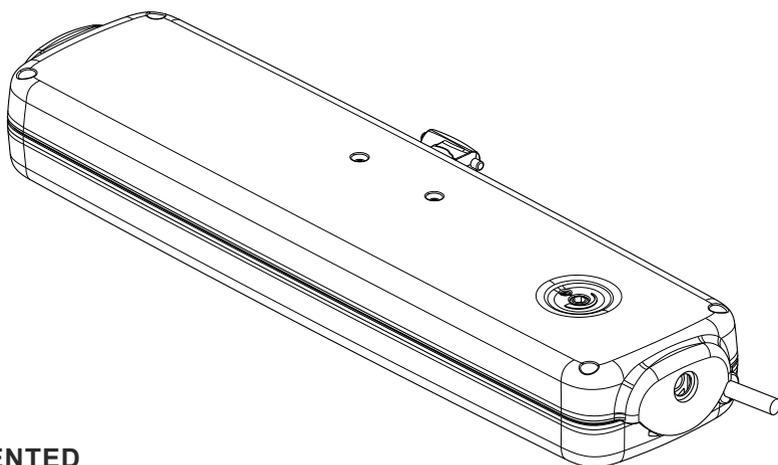

PATENTED



COD. 0P5321

VER.0.0

REV.06.20

**BEFORE INSTALLING AND USING THE ACTUATOR, IT IS
COMPULSORY FOR THE INSTALLER AND THE USER TO READ
AND UNDERSTAND THIS MANUAL IN ALL ITS PARTS.**

**THIS MANUAL IS INTEGRAL PART OF THE ACTUATOR
AND MUST BE PRESERVED FOR FUTURE REFERENCE
UNTIL DEMOLITION OF THE SAME.**

1- EC DECLARATION OF INCORPORATION OF PARTLY COMPLETED MACHINERY	page 04
2- GENERAL REMARKS	
2.1- General instructions.....	page 05
2.2- Installer and user.....	page 05
2.3- Technical assistance.....	page 05
2.4- Reserved rights.....	page 06
2.5- Description of personnel.....	page 06
3- TECHNICAL DESCRIPTION	
3.1- Rating plate and "CE" marking.....	page 07
3.2- Denomination of the components and dimensions.....	page 08
3.3- Technical data.....	page 09
3.4- Formulas for the calculation of thrust force or tractive force.....	page 10
3.5- Destination of use.....	page 10
3.6- Use Limits.....	page 11
3.7- Standard Package.....	page 11
4- SAFETY	
4.1- General instructions.....	page 13
4.2- Safety Devices.....	page 13
4.2.1- Protections against electric hazard.....	page 13
4.3- Safety plates.....	page 14
4.4- Residual risks.....	page 14
5- INSTALLATION	
5.1- General instructions.....	page 15
5.2- Top hung windows.....	page 18
5.3- Bottom hung windows.....	page 19
5.4- Electrical Connections.....	page 21
5.5- Control devices.....	page 22
5.6- Emergency procedures.....	page 23
6- USE AND OPERATION	
6.1- Use of the actuator.....	page 24
6.2- Smart Reset System (SAI).....	page 25
7- MAINTENANCE	
7.1- General instructions.....	page 26
8- DEMOLITION	
8.1- General instructions.....	page 26
9- SPARE PARTS AND ACCESSORIES UPON REQUEST	
9.1- General instructions.....	page 26
FIGURES	
.....	page 27

ORIGINAL



The undersigned, in the name of and
behalf of the following company

Topp S.r.l.
Via Galvani, 59
36066 Sandrigo (VI)
Italia

herewith declares that the person authorised to compile the technical file is

Name: *Bettiati Roberto - Topp S.r.l.*
Address: *via Galvani,59 36066 Sandrigo (VI)*

and that to the partly completed machinery

CHAIN ACTUATOR FOR WINDOW AUTOMATION

Type: **C40S**
Model: **C40S/230V - C40S/24V**

the following essential requisites of the

2006/42/EC Machinery Directive (including all applicable amendments)

have been applied and fulfilled: *Enclosure I: 1.5.1; 1.5.2; 1.5.10; 1.5.11*

that the relevant technical documentation is compiled in accordance with part B of Annex VII of the above mentioned Machinery Directive..

The above identified partly completed machinery is also in conformity with the all the relevant provisions of the following directives (including all applicable amendments)

EMC Directive 2014/30/EU
RoHS II Directive 2011/65/EU

The following harmonised standards have been applied:

EN 60335-2-103:2015 (applicable parts)
EN 55014-1:2006 + A1:2009 + A2:2011
EN 55014-2:2015
EN 61000-6-2:2005.
EN 61000-6-3:2007 + A1:2011 + AC:2012.
EN 50581:2012
and the following technical documents:
EN 62233:2008

The undersigned also undertakes the obligation, in response to a duly reasoned request by the national market surveillance authorities, to transmit to the a.m. authorities, in electronic or paper format, the relevant technical documentation on the partly completed machinery.

The above identified partly completed machinery must not be put into service until the final machinery into which it is to be incorporated has been declared in conformity with the provisions of the above mentioned Machinery Directive.

This declaration of conformity is issued under the sole responsibility of the manufacturer.

Date: Sandrigo01/02/2018

Signature: Matteo Cavalcante
Amministratore

2.1- GENERAL INSTRUCTIONS



BEFORE INSTALLING AND USING THE ACTUATOR, IT IS COMPULSORY THAT THE INSTALLER AND THE USER CAREFULLY READ AND UNDERSTAND THIS MANUAL IN ALL ITS PARTS.



THIS MANUAL IS INTEGRAL PART OF THE ACTUATOR AND MUST COMPULSORILY BE PRESERVED FOR FUTURE REFERENCE.



THE MANUFACTURER HAS NO LIABILITY FOR ANY EVENTUAL DAMAGE TO PERSONS, ANIMALS AND THINGS DUE TO THE INOBSERVANCE OF THE PRESCRIPTIONS DESCRIBED IN THIS MANUAL.



IN ORDER FOR THE AUTOMATION UNIT TO OPERATE CORRECTLY, WE RECOMMEND CARRYING OUT PERIODICAL MAINTENANCE ON IT, AS INDICATED IN PAR. 7.1 OF THIS MANUAL.



THE WARRANTY ON THE ACTUATOR WILL NOT BE HONORED IF PRODUCT IS NOT INSTALLED AND USED ACCORDING TO THE INSTRUCTIONS PROVIDED AND THE REGULATIONS SHOWN IN THIS INSTRUCTION MANUAL AND IF IT IS USED WITH NON-GENUINE PARTS, ACCESSORIES, SPARE PARTS AND/OR CONTROL/FEEDING UNITS.

2.2- INSTALLER AND USER



THE ACTUATOR INSTALLATION CAN BE PERFORMED EXCLUSIVELY BY COMPETENT AND QUALIFIED TECHNICAL PERSONNEL SATISFYING THE PROFESSIONAL AND TECHNICAL REQUIREMENTS FORESEEN BY THE LAWS IN FORCE IN THE COUNTRY OF INSTALLATION.



THE INSTALLATION TECHNICIAN SHALL ACCEPT FULL RESPONSIBILITY FOR ANY INSTALLATION ERRORS AND FOR ANY FAILURE TO ADHERE TO THE INSTRUCTIONS PROVIDED IN THIS MANUAL. THE INSTALLATION TECHNICIAN SHALL THEREFORE BE EXCLUSIVELY LIABLE FOR ANY DAMAGES CAUSED TO USERS AND/OR THIRD PARTIES THAT MAY ARISE AS A RESULT OF INCORRECT INSTALLATION.



THE ACTUATOR CAN BE USED EXCLUSIVELY BY A USER ACTING IN COMPLIANCE WITH THE INSTRUCTIONS CONTAINED IN THIS MANUAL AND/OR IN THE MANUAL OF THE ACTUATOR CONTROL DEVICE (e.g.: CONTROL UNIT).

2.3- TECHNICAL ASSISTANCE

Contact the installation technician or retailer for assistance.

2.4- RESERVED RIGHTS

The reserved rights on this manual "Installation and use instructions" remain property of the Manufacturer.

Each information herein contained (text, drawings, diagrams, etc.) is reserved.

None part of this manual can be reproduced and disclosed (totally or partially) by any reproduction means (photocopies, microfilms or other) without written authorization of the Manufacturer.

2.5- DESCRIPTION OF PERSONNEL



USERS MUST NEVER PERFORM OPERATIONS RESERVED FOR MAINTENANCE PEOPLE OR SPECIALISED TECHNICIANS. THE MANUFACTURER DECLINES ALL LIABILITY FOR DAMAGE DERIVING FROM FAILURE TO OBSERVE THE ABOVE REQUIREMENTS.

Specialised electrician:

A specialised electrician must be able to install the actuator, start it and operate it both in normal conditions and in the maintenance mode; he/she is qualified to perform all electrical and mechanical adjustment and maintenance operations. He/she is allowed to work on live electrical cabinets and junction boxes.

User:

specialised person capable of operating the actuator under normal conditions by using the relative controls. He/she must also be able to operate with the actuator under "maintenance" in order to perform simple routine maintenance operations (cleaning), and start or reset the actuator following an unscheduled stop.

3.1- RATING PLATE AND "CE" MARKING

The "CE" marking certifies the compliance of the machine with the essential safety and health requirements foreseen by the product European Directives.

The rating plate is an adhesive plate in polyester, silk-screen printed in black, having the following size: L= 36 mm - H= 50 mm.

It is applied externally on the actuator. The plate bears in readable and indelible way the following data:

- logo and address of the manufacturer
- type and model
- voltage and intensity of power supply (V - A)
- absorbed electric power P (W)
- thrust and tractive force F (N)
- type of service S_2 (min)
- idle translation speed (mm/s)
- protection degree (IP)
- "CE" marking
- symbol of WEEE Directive 2002/96/CE
- symbol of double insulation (only for mod. C40S/230V)
- serial number

3.2- DENOMINATION OF THE COMPONENTS AND DIMENSIONS

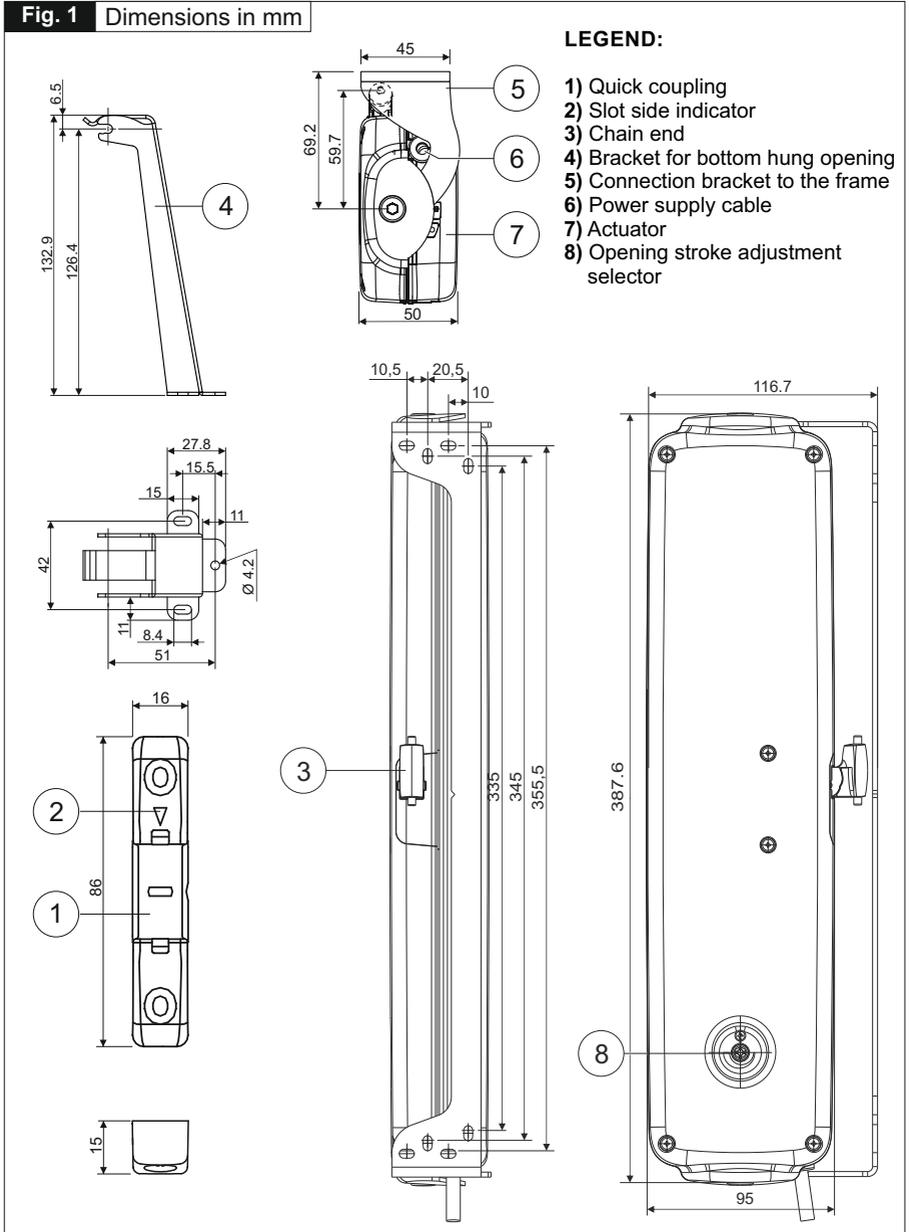

3.3- TECHNICAL DATA

Tab. 1

Tab. 1 contains the technical data characterising the actuators.

		C40S/230V	C40S/24V
POWER SUPPLY VOLTAGE		230 V ~ 50 Hz	24 V ± 10%
ABSORBED CURRENT		0,22 A	0,63 A
ABSORBED POWER WITH LOAD		35 W	15 W
PROTECTION AGAINST ELECTRIC SHOCKS		Class II	Class III
PROTECTION DEGREE OF ELECTRIC DEVICES		IP55	
PARALLEL CONNECTION OF MORE THAN ONE ACTUATOR		YES (see wiring diagram)	
MAXIMUM APPLICABLE THRUST LOAD	Top hung		
	Horizontal domes or skylights	400 N	350 N
MAXIMUM APPLICABLE TRACTIVE LOAD		400 N	350 N
MAXIMUM THRUST LOAD APPLICABLE ON TWO SYNCHRONIZED AUTOMATIONS.		700 N	600 N
MAXIMUM TRACTIVE LOAD APPLICABLE ON TWO SYNCHRONIZED AUTOMATIONS.		700 N	600 N
IDLE TRANSLATION SPEED		7,7 mm/s	7,7 mm/s
DURATION OF THE IDLE STROKE		65 s	65 s
TYPE OF SERVICE S2 ⁽¹⁾		5 min	5 min
ADJUSTABLE STROKES ON OUTLET ⁽²⁾		100-150-200-250-300-400-500 mm	
MAX. OVERLAPPED PART "D"		80 mm	
OPERATING TEMPERATURE		-5°C ÷ 50°C	
ACTUATOR WEIGHT WITH BRACKETS		1,9 Kg	
GROSS WEIGHT		2,1 kg	
SYNCHRONIZ. TWO ACTUATORS ON THE SAME WINDOW		YES	
ADJUSTABLE STROKES ON OUTLET	STROKE	MINIMUM HEIGHT OF THE WINDOW FRAME ⁽³⁾ Top hung	MINIMUM HEIGHT OF THE WINDOW FRAME ⁽³⁾ Bottom hung
1	100 mm	300 mm	300 mm
2	150 mm	300 mm	300 mm
3	200 mm	300 mm	300 mm
4	250 mm	300 mm	400 mm
5	300 mm	350 mm	500 mm
6	400 mm	450 mm	900 mm
7	500 mm	500 mm	1000 mm
MINIMUM DISTANCE BETWEEN ACTUATOR			60 mm

⁽¹⁾ Service of limited duration according to EN 60034

⁽²⁾ Tolerance on the tripping precision of the limit switch at output: +/- 10 mm

⁽³⁾ Distance of the actuator from the window opening hinge

3.4- FORMULAS FOR THE CALCULATION OF THRUST AND TRACTIVE FORCE

Fig. 2

Horizontal domes or skylights

$F_{(N)}$ = Force necessary for opening or closing

$P_{(N)}$ = Weight of the skylight or dome
(Only movable part)

$$F = 0,54 \times P$$

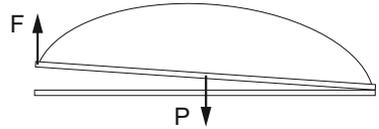

Fig. 3

Top hung windows (A) or bottom hung windows (B)

$F_{(N)}$ = Force necessary for opening or closing

$P_{(N)}$ = Weight of the window
(only movable part)

$C_{(mm)}$ = Window opening stroke

$H_{(mm)}$ = Window height

$$F = (0,54 \times P) \times \left(\frac{C}{H} \right)$$

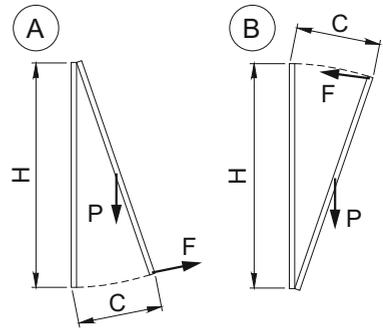

3.5- DESTINATION OF USE



THE ACTUATOR HAS BEEN DESIGNED AND MANUFACTURED TO PERFORM, BY MEANS OF A CONTROL DEVICE, THE OPENING AND CLOSING OF TOP HUNG WINDOWS, BOTTOM HUNG WINDOWS, PIVOT WINDOWS, AND SKYLIGHTS.

The **C40S** Chain actuator is equipped with the latest TOPP system for the coordinated synchronization of the chain movement. The electronic speed control is fully automatic and requires no external control unit; just connect the yellow/white/blue cables as per wiring diagram at the back of the manual to achieve the synchronized mode. **The Smart Reset System (SAI)** has also been included which adjusts the closure of the window in an optimum manner.

The **C40S** chain actuator is mounted when you need two or more attachment points because the window is particularly heavy or wide and only one actuator would not allow perfect closure of the window. It should be remembered that the force exerted by the actuators individually is the same as a similar **C40** actuator; for example, by mounting two actuators the force applied to the window is, therefore, doubled. The window is moved in a uniform, synchronized and coordinated manner with no interruptions and/or speed changes in the actuators' operation. In the event of any failure of one of the actuators due to a mechanical or electrical fault, the others also stop operating, guaranteeing that the window remains intact.

3.6- USE LIMITS

The actuator has been designed and manufactured exclusively for the destination of use given in **par. 3.5**, therefore, any other type of use is strictly forbidden in order to assure in any moment the safety of the installer and of the user, as well as the efficiency of the actuator itself.

Check carefully all environmental conditions (temperature, humidity, wind, snow, potential chemical agents, etc.) and installation settings (misaligned fitting of brackets and attachment to the frame, frictions produced by hinges or gaskets, use of self-balancing window stays, etc.) it is recommended that they not exceed the actuator performances shown in the technical table.



IT IS STRICTLY FORBIDDEN TO USE THE ACTUATOR FOR IMPROPER USES OTHER THAN THE ONE FORESEEN BY THE MANUFACTURER (SEE PAR. 3.5).



IT IS STRICTLY FORBIDDEN TO INSTALL THE ACTUATOR ON THE EXTERNAL SIDE OF THE WINDOW FRAME SUBJECT TO ATMOSPHERIC AGENTS (RAIN, SNOW, ETC.).



THE USE OF THE ACTUATOR IN ENVIRONMENTS WITH POTENTIALLY EXPLOSIVE ATMOSPHERE IS STRICTLY FORBIDDEN.



IT IS COMPULSORY TO KEEP THE PACKAGE AND THE ACTUATOR OUT OF REACH OF CHILDREN.

3.7- STANDARD PACKAGE

Each standard package of the product (cardboard box) contains (**Fig. 4**):

- No.1 Actuator equipped with power supply cable;
- No.1 Window frame connection bracket (**Ref. A**);
- No.1 Bracket for bottom hung opening (**Ref. B**);
- No.1 Small part package (quick coupling (Ref.1), No.2 bracket fastening lateral screws and No. 7 AF Ø 4.2 x 19 mm screws for window frame bracket fastening and leaf bracket fastening);
- No. 1 Adhesive drilling template (**Ref. D**);
- No. 1 Installation and use instructions (**Ref. E**);
- No.1 Safety Plate (**Fig. 5**).



MAKE SURE THAT THE ABOVE DESCRIBED COMPONENTS ARE CONTAINED IN THE PACKAGE, AS WELL AS THAT THE ACTUATOR HAS NOT BEEN DAMAGED DURING TRANSPORT.



SHOULD ANY ANOMALY BE DETECTED, IT IS FORBIDDEN TO INSTALL THE ACTUATOR, AND IT IS COMPULSORY TO REQUIRE TECHNICAL ASSISTANCE FROM YOUR DEALER OR THE MANUFACTURER.



THE PACKAGING (PAPER, PLASTIC, ETC.) HAS TO BE DISPOSED ACCORDING TO THE LAWS IN FORCE.

Fig. 4

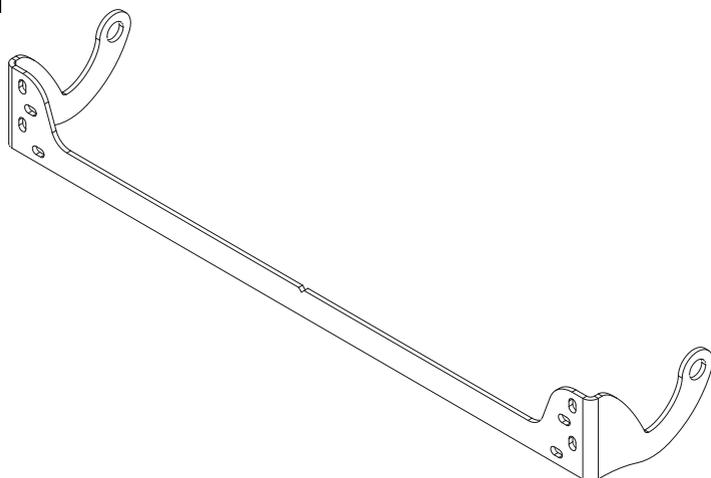

A

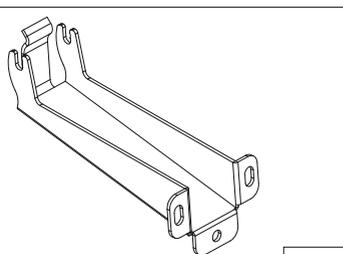

B

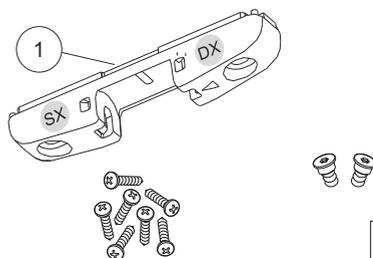

C

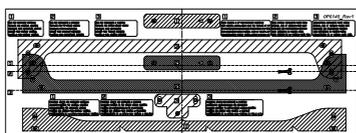

D



E

4.1- GENERAL INSTRUCTIONS



OPERATORS MUST BE INFORMED OF ACCIDENT RISKS, SAFETY DEVICES AND THE GENERAL ACCIDENT PREVENTION REGULATIONS ESTABLISHED BY INTERNATIONAL DIRECTIVES AND BY THE LAW IN FORCE IN THE COUNTRY OF USE. ALL OPERATORS MUST STRICTLY COMPLY WITH THE ACCIDENT PREVENTION REGULATIONS IN FORCE IN THE COUNTRY OF USE.



DURING HANDLING AND INSTALLATION OF THE PARTS, THE PERSONNEL SHALL BE EQUIPPED WITH SUITABLE PERSONAL PROTECTION EQUIPMENT (PPE) SO AS TO PERFORM THE WORKS REQUIRED UNDER SAFE CONDITIONS.



DO NOT REMOVE OR ALTER THE PLATES PLACED ON THE ACTUATOR BY THE MANUFACTURER.



IF THE WINDOW FRAME IS ACCESSIBLE FROM OR INSTALLED AT A HEIGHT OF LESS THAN 2.5 m FROM THE GROUND, AND IF IT CAN BE COMMANDED BY AN UNTRAINED USER OR WITH A REMOTE CONTROL DEVICE, FIT AN EMERGENCY STOP SYSTEM WHICH AUTOMATICALLY CUTS IN TO PREVENT THE RISK OF CRUSHING OR DRAGGING PARTS OF THE BODY INSERTED BETWEEN THE MOVING AND FIXED PARTS OF THE WINDOW FRAME.



ANY TAMPERING WITH OR UNAUTHORISED REPLACEMENT OF ONE OR MORE PARTS OR COMPONENTS OF THE ACTUATOR, OR THE USE OF UNORIGINAL ACCESSORIES AND CONSUMABLES, MAY INCREASE THE RISK OF ACCIDENT AND THUS RELIEVES THE MANUFACTURER OF ALL CIVIL AND PENAL LIABILITY



EXTRAORDINARY AND ROUTINE MAINTENANCE OPERATIONS INVOLVING THE TOTAL OR PARTIAL DISMOUNTING OF THE ACTUATOR MAY ONLY BE PERFORMED AFTER DISCONNECTING IT FROM THE POWER SUPPLY.



THIS APPLIANCE MAY NOT BE USED BY PERSONS (CHILDREN INCLUDED) WITH REDUCED PHYSICAL, SENSORIAL OR MENTAL CAPACITIES, OR INEXPERT PEOPLE, UNLESS THEY ARE SUPERVISED AND TAUGHT HOW TO USE IT BY A PERSON RESPONSIBLE FOR THEIR SAFETY. CHILDREN MUST BE CONTROLLED TO MAKE SURE THEY DO NOT PLAY WITH THE APPLIANCE.

4.2- SAFETY DEVICES

4.2.1- PROTECTION AGAINST ELECTRIC HAZARD

The actuator is protected against electric hazard due to direct and indirect contacts.

The protection measures against direct contacts aim at protecting people against hazards due to contact with active parts, usually live parts; while the protection measures against indirect contacts aim at protecting people against hazards due to conducting part, which are usually insulated, but could become live in case of failure (insulation failure).

The adopted protection measures are the following:

- 1) Insulation of live parts by means of a plastic material body;

2) Enclosure with suitable protection degree;

3) **Only for Mod. C40S/230 V equipped with double insulation:** Protection of passive type given by the use of components with double insulation, also called components of class II or with equivalent insulation. (It is forbidden to connect the actuators equipped with double insulation to the earth plant.

4.3- SAFETY PLATES



IT IS FORBIDDEN TO REMOVE, MOVE, SPOIL OR IN ANYWAY REDUCE THE VISIBILITY OF THE SAFETY PLATES. FAILURE TO OBSERVE THE ABOVE MAY CAUSE SERIOUS HARM TO PEOPLE AND DAMAGE TO PROPERTY. THE MANUFACTURER DECLINES ALL LIABILITY FOR ANY DAMAGE CAUSED BY THE FAILURE TO OBSERVE THE ABOVE REQUIREMENT.

Fig. 5 illustrates the safety plate: this must be applied directly to the outside of the actuator or near it and always in a position where it can be seen by the installer and/or operator.

4.4- RESIDUAL RISKS

The installer and the user are herewith informed that after the actuator has been installed on the window, the actuator drive can accidentally generate the following residual risk:

Residual risk: Hazard of squashing or dragging of body parts inserted between the movable and the fix part of the window frame.

Exposure frequency: Accidental and when the installer or the user decides to perform a wrong voluntary action.

Severity of the damage: Light lesions (usually reversible).

Adopted measures: Before enabling the device, it is compulsory to verify that near the window there are not persons, animals or things whose safety may be accidentally jeopardized. During actuator operation, it is compulsory to be in a safe control position assuring visual control on the window movement (**see par. 6.1**).

Fig. 5



MACCHINA AD AVVIAMENTO AUTOMATICO
AUTOMATIC MACHINE



PRIMA DI INSTALLARE E UTILIZZARE L'ATTUATORE È OBBLIGATORIO CHE L'INSTALLATORE E L'UTILIZZATORE LEGGANO E COMPENDANO IN TUTTE LE SUE PARTI IL MANUALE
THE INSTALLER AND USER MUST READ AND UNDERSTAND ALL PARTS OF THIS MANUAL BEFORE INSTALLING AND USING THE ACTUATOR.



PERICOLO ATTENZIONE ALLE MANI
BEWARE OF YOUR HANDS



ATTENZIONE MACCHINA AD AVVIAMENTO AUTOMATICO CON COMANDO A DISTANZA
ATTENTION! AUTOMATIC MACHINE WITH REMOTE CONTROL DEVICE

IT
EN

5.1- GENERAL INSTRUCTIONS



THE ACTUATOR INSTALLATION CAN BE PERFORMED EXCLUSIVELY BY COMPETENT AND QUALIFIED TECHNICAL PERSONNEL SATISFYING THE PROFESSIONAL AND TECHNICAL REQUIREMENTS FORESEEN BY THE LAWS IN FORCE IN THE COUNTRY OF INSTALLATION.



THE ACTUATOR PERFORMANCE MUST BE SUFFICIENT TO ASSURE THE CORRECT MOVEMENT OF THE WINDOW. IT IS COMPULSORY TO VERIFY THE THRUST OR TRACTIVE FORCE ACCORDING TO THE TYPE AND WEIGHT OF THE WINDOW (PAR. 3.4). IT IS FORBIDDEN TO EXCEED THE LIMITS GIVEN IN TAB. 1 CONCERNING THE TECHNICAL DATA (PAR. 3.3).



THE ACTUATOR INSTALLATION MUST BE PERFORMED EXCLUSIVELY WITH CLOSED WINDOW OR SKYLIGHT.



BEFORE PERFORMING THE INSTALLATION OF THE ACTUATOR ON HOPPER WINDOWS, VERIFY THAT ON BOTH SIDES OF THE WINDOW TWO COMPASS STROKE LIMIT DEVICES ARE INSTALLED IN ORDER TO AVOID THE ACCIDENTAL FALL OF THE WINDOW.



FOR CORRECT OPERATION OF THE ACTUATOR, THE WINDOW FRAME MUST HAVE A MINIMUM HEIGHT AS QUOTED IN THE TABLE OF FIG. 6a FOR THE TOP HUNG ASSEMBLY AND IN THE TABLE OF FIG. 6b FOR THE BOTTOM HUNG ASSEMBLY.



VERIFY THAT THE POSITIONS OF THE LABELS LOCATED ON THE QUICK COUPLING CORRESPOND TO THE LABELS ON THE ACTUATOR: RED LABEL WITH LETTER "A" FOR THE TOP HUNG ASSEMBLY, GREEN LABEL WITH LETTER "B" FOR VERTICAL ASSEMBLY.



VERIFY THAT THE DISTANCE "D" BETWEEN THE FRAME OF THE WINDOW FRAME (ON WHICH THE FIXING OF THE ACTUATOR IS FORESEEN) AND THE WING OF THE WINDOW FRAME (ON WHICH THE FASTENING OF THE BRACKET IS FORESEEN) IS INCLUDED BETWEEN 0 AND 80 mm BOTH FOR THE TOP HUNG ASSEMBLY (SEE FIG 6a) AND FOR THE BOTTOM HUNG ASSEMBLY (SEE FIG 6b).



THE FITTING SURFACE FOR THE ARS RAPID COUPLING DEVICE MUST BE PERFECTLY FLAT AND/OR SMOOTH.



CHECK THE ADEQUACY OF THE WINDOW AND THE SUITABILITY OF THE MATERIALS OF THE WINDOW AND/OR FRAME ON WHICH THE ACTUATOR WILL BE FASTENED. AND IT MUST ENSURE A GOOD SUPPORT OF THE ACTUATOR-WINDOW ASSEMBLY DURING THE MOVEMENT.

Fig. 6a

TOP HUNG OPENING		
POS.	STROKE (mm)	WINDOW MIN HEIGHT (mm)
1	100	300
2	150	
3	200	
4	250	
5	300	350
6	400	450
7	500	500

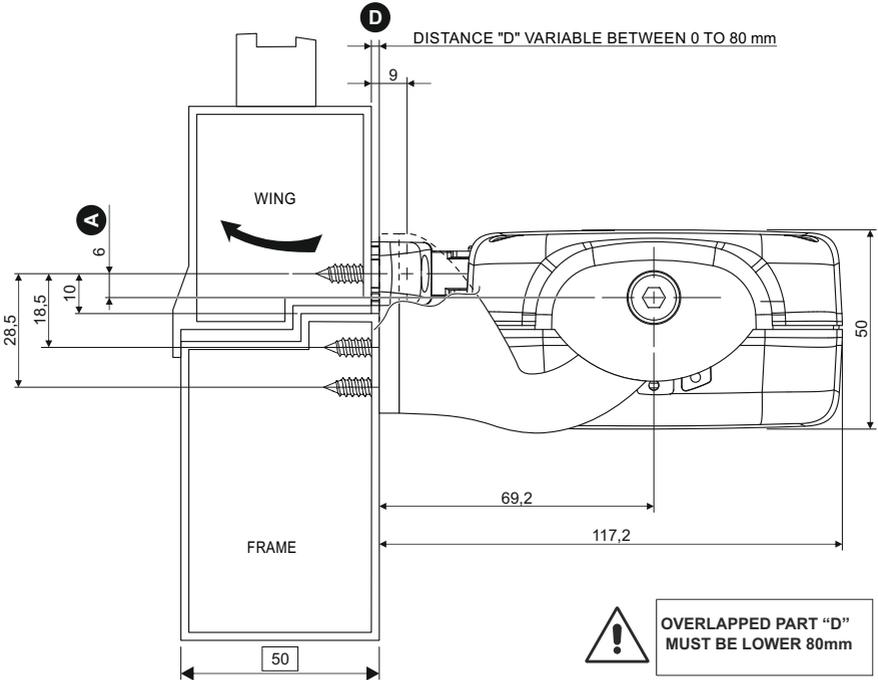

THE FASTENING POSITION **A** HAS TO BE VERIFIED AND EVALUATED ACCORDING TO THE PROFILE/LENGTH OF THE WING/FRAME AND OF THE WINDOW LIGHT.

Fig. 6b

BOTTOM HUNG OPENING		
POS.	STROKE (mm)	WINDOW MIN HEIGHT (mm)
1	100	300
2	150	
3	200	
4	250	400
5	300	500
6	400	900
7	500	1000

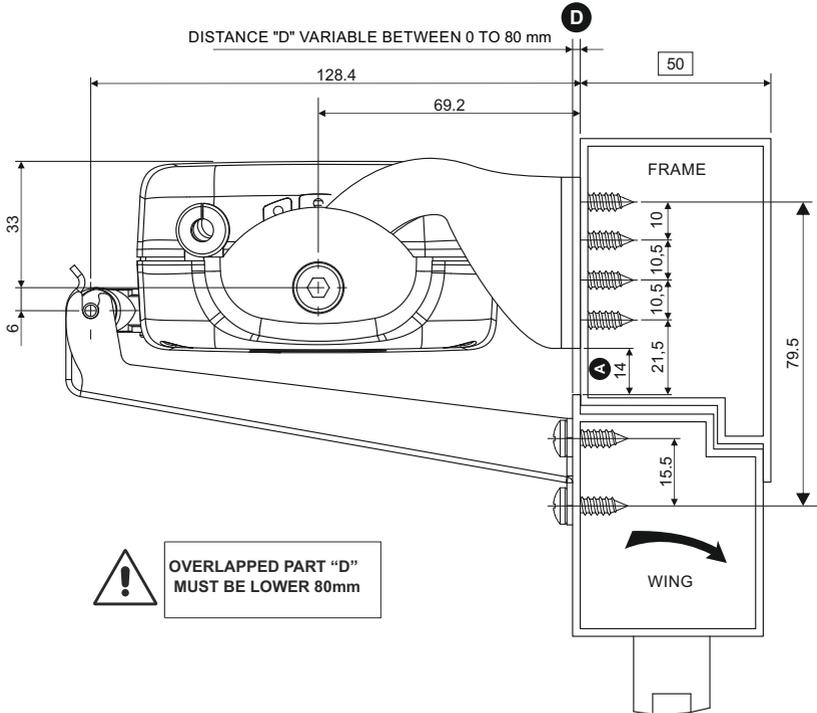

THE FASTENING POSITION **A** HAS TO BE VERIFIED AND EVALUATED ACCORDING TO THE PROFILE/LENGTH OF THE WING/FRAME AND OF THE WINDOW LIGHT.

5.2- TOP HUNG WINDOWS (Fig. 7 and Fig. 13 ÷ 20)

- 1) Open the package (par. 3.7) and extract the various components;
- 2) **Fig. 13-** With a pencil draw the centre line "X" of the window frame;
- 3) **Fig. 14-** Apply the template (POS.2) on the window frame aligning it with the previously drawn centre line "X";

Fig. 7

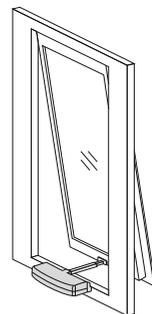

CAUTION: FOR NON-COPLANAR WINDOW FRAMES, IT IS NECESSARY TO CUT THE TEMPLATE CONCERNED PART AND TO APPLY IT ON THE WINDOW FRAME PAYING ATTENTION TO KEEP IT IN THE SAME REFERENCE POSITION.

- 4) **Fig. 15-** With a suitable drill, create on the window frame holes having the related diameter, given on the template;
- 5) **Fig. 16/17-** With the suitable screws tighten the bracket for window frame connection and the quick coupling;
- 6) **Fig. 18-** With an Allen wrench, adjust the opening stroke by means of a proper selector (**Ref. 1**) (for tandem installations, the actuators must have the same stroke).



CAUTION: VERIFY THAT THE SELECTED STROKE IS SOME CENTIMETRES LOWER THAN THE STROKE EFFECTIVELY ALLOWED BY MECHANICAL LOCKS, COMPASS LIMIT DEVICES OR WING OPENING HINDRANCES.

- 7) Hook the system up electrically as indicated in **par. 5.4** and the wiring diagram (for tandem installations, complete the hookup per the wiring diagram before running the chain out). Run the chain out for at least 10 cm, then disconnect the actuator from its power supply.



VERIFY THAT THE CHAIN ADJUSTMENT END (FIG.8 - Ref. A) IS ON THE SAME AXIS OF THE QUICK COUPLING (FIG.8 - Ref. B). OTHERWISE, REPEAT THE OPERATIONS AND POSITION CORRECTLY; WHEN THEY ARE NOT COAXIAL, THIS MAY DAMAGE THE ACTUATOR AND THE WINDOW FRAME (FIG. 8).

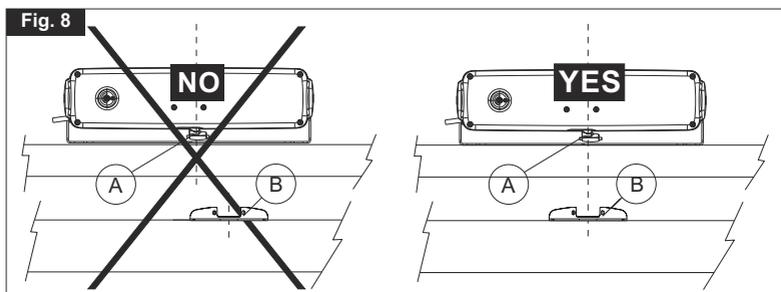

- 8) **Fig. 19-** Connect the actuator to the semi-automatic coupling inserting the chain adjustment end first of all in the left connection point (**Ref. 2**) and then in the right connection point (**Ref. 1**);
- 9) **Fig. 20-** Using the two supplied screws (**Ref. 1**) tighten the actuator to the window frame connection bracket in the most suitable position according to the value of the overlapped part "D" (**see Fig. 6a**).



FOR APPLICATION TANDEM ENSURE THAT THE ACTUATORS ARE MOUNTED ON THE SAME HOLE OF THE ATTACHMENT BRACKET TO THE WINDOW FRAME

- 10) Repeat with the second actuator.
- 11) Power up the actuators.
- 12) Perform a test of complete window frame opening and closing. After the closing phase, verify that the chain end is completely returned in its seat;

5.3- BOTTOM HUNG WINDOWS (Fig. 10 and 21 ÷ 28)

- 1) Open the package (**par. 3.7**) and extract the various components;
- 2) **Fig. 21-** With a pencil draw the centre line "Y" of the window frame;
- 3) **Fig. 22-** Apply the template (**Ref. 1**) on the window frame aligning it with the previously drawn centre line "Y";

Fig. 10

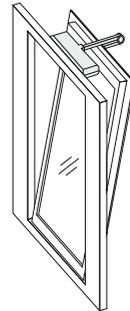

CAUTION: FOR NON-COPLANAR WINDOW FRAMES, IT IS NECESSARY TO CUT THE TEMPLATE CONCERNED PART AND TO APPLY IT ON THE WINDOW FRAME PAYING ATTENTION TO KEEP IT IN THE SAME REFERENCE POSITION.

- 4) **Fig. 23-** With a suitable drill, create on the window frame holes having the related diameter, given on the template;
- 5) **Fig. 24/25 -** With the suitable screws tighten the bracket for window frame connection and the bottom hung opening bracket;

- 6) **Fig. 26-** Adjust the opening stroke by the switch (**Ref. 1**) located on the right side of the actuator according to the opening of the wing and tighten the chain end adjustment screw;



CAUTION: VERIFY THAT THE SELECTED STROKE IS SOME CENTIMETRES LOWER THAN THE STROKE EFFECTIVELY ALLOWED BY MECHANICAL LOCKS, COMPASS LIMIT DEVICES OR WING OPENING HINDRANCES.

- 7) Hook the system up electrically as indicated in **par. 5.4** and the wiring diagram (for tandem installations, complete the hookup per the wiring diagram before running the chain out). Run the chain out for at least 10 cm, then disconnect the actuator from its power supply.
- 8) **Fig. 27-** Connect the chain end to the bottom hung bracket;
- 9) **Fig. 28-** Using the two supplied screws (**Ref. 1**) tighten the actuator to the window frame connection bracket in the most suitable position according to the value of the overlapped part "D" (**see Fig. 6b**).



FOR APPLICATION TANDEM ENSURE THAT THE ACTUATORS ARE MOUNTED ON THE SAME HOLE OF THE ATTACHMENT BRACKET TO THE WINDOW FRAME

- 10) Repeat with the second actuator.
- 11) Power up the actuators.
- 12) Perform a test of complete window frame opening and closing. After the closing phase, verify that the chain end is completely returned in its seat;

5.4- ELECTRIC CONNECTIONS (Wiring diagram)



THE ELECTRIC CONNECTION OF THE ACTUATOR CAN BE PERFORMED ONLY BY COMPETENT AND QUALIFIED TECHNICAL PERSONNEL FORESEEN BY THE LAW IN FORCE IN THE COUNTRY OF INSTALLATION WHO CAN ISSUE TO THE CUSTOMER A DECLARATION OF CONFORMITY FOR THE CONNECTION AND/OR PLANT CARRIED OUT.



BEFORE PERFORMING THE ELECTRIC CONNECTION OF THE ACTUATOR, VERIFY THE CORRECT INSTALLATION ON THE WINDOW.



THE ELECTRICAL CONNECTION OF THE VERSION C40S/230V MUST BE COMPLETED INTO A SUITABLE AND APPROPRIATE JUNCTION BOX. THE COMMUNICATION CABLES HAVE TO BE PLACED INTO THE SAME JUNCTION BOX WHERE ELECTRICAL CABLES ARE



THE CONNECTION OF MODEL C40S/24V HAS TO BE CARRIED OUT WITH VERY LOW VOLTAGE SAFETY FEEDER PROTECTED AGAINST SHORT CIRCUIT.



THE MAINS TO WHICH THE ACTUATOR IS CONNECTED MUST COMPLY WITH THE REQUIREMENTS OF THE LAWS IN FORCE IN THE COUNTRY OF INSTALLATION, AS WELL AS SATISFY THE TECHNICAL FEATURES GIVEN IN TAB. 1 AND ON THE RATING PLATE AND THE "CE" MARKING (PAR. 3.1), AS WELL AS BE EQUIPPED WITH A SUITABLE "EARTHING PLANT".



THE SECTION OF THE MAINS CABLES MUST BE PROPERLY SIZED ACCORDING TO THE ABSORBED ELECTRIC POWER (SEE RATING PLATE AND "CE" MARKING).



ANY TYPE OF ELECTRIC MATERIAL (PLUG, CABLE, TERMINALS, ETC.) USED FOR THE CONNECTION MUST BE SUITABLE FOR THE USE, WITH "CE" MARKING, AND COMPLYING WITH THE REQUIREMENTS FORESEEN BY THE LAWS IN FORCE IN THE COUNTRY OF INSTALLATION.



TO ASSURE AN EFFICIENT SEPARATION FROM THE MAINS, IT IS COMPULSORY TO INSTALL UPSTREAM OF THE DEVICE A TEMPORARY BIPOLAR SWITCH (PUSH-BUTTON) OF APPROVED TYPE. UPSTREAM OF THE COMMAND LINE, IT IS COMPULSORY TO INSTALL A UNIPOLAR MAIN SWITCH WITH OPENING OF CONTACTS OF AT LEAST 3 mm.



BEFORE MAKING ANY ELECTRICAL CONNECTIONS ON THE ACTUATOR, MAKE SURE THE POWER SUPPLY CABLE IS NOT DAMAGED. IF THE CABLE IS DAMAGED, THEN IT MUST BE REPLACED BY THE MANUFACTURER THROUGH THE TECHNICAL ASSISTANCE SERVICE OR BY TECHNICAL OPERATORS.

5.5- CONTROL DEVICES



THE CONTROL DEVICES USED TO DRIVE THE ACTUATOR MUST ASSURE THE SAFETY CONDITIONS FORESEEN BY THE LAWS IN FORCE IN THE COUNTRY OF USE.

According to the different type of installations, the actuators can be driven by the following control devices:

1) MANUAL PUSH-BUTTON:

Bipolar switch button with central off position, with biased-off switch;

2) OPTIONAL: CONTROL AND FEEDING UNIT:

TOPP Microprocessor control units (e.g.: Mod. **TF44**, etc.) controlling the single actuator (**C40S/230V**) or more than one actuator simultaneously (**C40S/230V**) or by means of one or more manual pushbuttons, an infrared remote control or a 433 Mhz radio control.

The electrical connection of the **C40S/24V** version must be made with a 24V power supply / control units of appropriate power.

To these control units, it is possible to connect the rain sensors (**RDC -12V**), the windsensor (**RW**) and the brightness sensor;



THE EVENTUALLY USED UNITS MUST SUPPLY A VOLTAGE TO C40S FOR MAX. 120 SECONDS.

5.6- EMERGENCY PROCEDURES

Should it be necessary to open the window manually due to power supply failure or mechanism block, follow these instructions:



BEFORE PERFORMING ANY TYPE OF INTERVENTION ON THE ACTUATOR AND ON THE WINDOW, IT IS COMPULSORY TO DISCONNECT THE POWER SUPPLY OF THE ACTUATOR AND TO PUT ON "0" THE EVENTUAL SWITCHES OF THE CONTROL DEVICES.



IT IS COMPULSORY TO PADLOCK THE MAIN SWITCH OF THE DISCONNECTION DEVICE INSTALLED ON THE MAINS IN ORDER TO AVOID ANY UNEXPECTED START. IF THE MAIN SWITCH CANNOT BE PADLOCKED, IT IS COMPULSORY TO PLACE A SIGN FORBIDDING THE ENABLING.



IN SOME CASES, THE EVENT OF POSSIBLE ANOMALIES MIGHT STALL ALSO OTHER ACTUATORS CONNECTED IN PARALLEL. TO FIND THE SUPPOSED MALFUNCTIONING ACTUATOR, RUN SOME CLOSING OPERATIONS IN SUCCESSION (ABOUT 10 OPERATIONS EVERY 2 SECONDS), TILL THE WORKING ACTUATORS START RUNNING AGAIN.

- **Top hung opening: Fig. 10-** Insert a screw driver in the right side opening (Ref. 1) of the quick coupling and lever on the reed holding the chain end and extract the above mentioned bracket.
- **Bottom hung opening: Fig. 11-** Insert a screw driver between the bracket for bottom hung opening and the chain end, then lever until the chain end disconnects from the above mentioned bracket.

Fig. 10

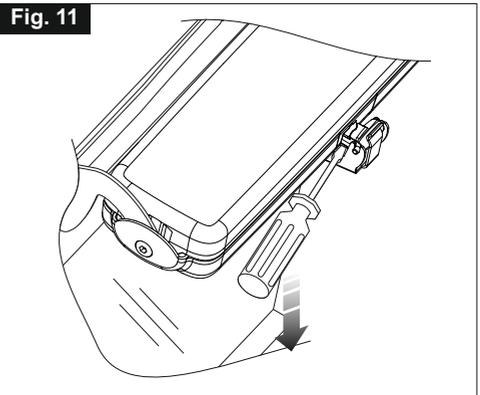
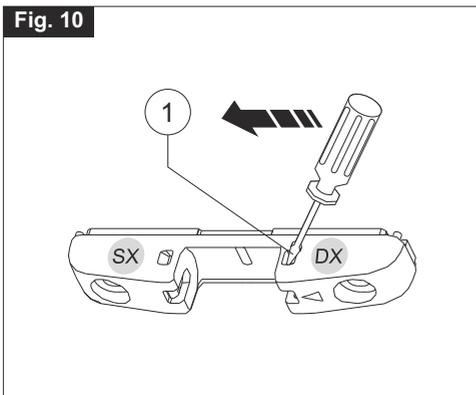

6.1- USE OF THE ACTUATOR



THE ACTUATOR CAN BE USED ONLY BY A USER ACTING IN COMPLIANCE WITH THE INSTRUCTIONS GIVEN IN THIS MANUAL AND/OR IN THE MANUAL OF THE ACTUATOR COMMAND DEVICE (e.g.: WIND AND RAIN CONTROL UNIT).



BEFORE USING THE ACTUATOR, IT IS COMPULSORY FOR THE USER TO READ AND UNDERSTAND IN ALL ITS PARTS THIS MANUAL, AS WELL AS THE EVENTUAL MANUAL OF THE INSTALLED CONTROL DEVICE TYPE.



DO NOT OPERATE DOME WINDOWS IN THE PRESENCE OF A LOAD OF SNOW IN EXCESS OF THE QUANTITY DECLARED ACCEPTABLE BY THE WINDOW MANUFACTURER.



BEFORE OPERATING THE ACTUATOR, THE USER MUST COMPULSORILY VERIFY THAT NEAR AND/OR UNDER THE WINDOW THERE ARE NOT ANY PERSON, ANIMAL AND THING WHOSE SAFETY MAY BE ACCIDENTALLY JEOPARDISED (SEE PAR. 4.4).



DURING THE OPERATION OF THE ACTUATOR CONTROL DEVICE, THE USER HAS TO COMPULSORILY OCCUPY A CONTROL POSITION ASSURING VISUAL CONTROL ON THE WINDOW MOVEMENT.



THE FUNCTION EFFICIENCY AND THE RATED PERFORMANCE OF THE ACTUATOR, OF THE WINDOW FRAME ON WHICH IT IS INSTALLED AND OF THE ELECTRIC EQUIPMENT MUST BE VERIFIED STEADILY IN TIME BY PERFORMING, WHEN NECESSARY, INTERVENTIONS OF ROUTINE AND SUPPLEMENTARY MAINTENANCE ASSURING THE OPERATION CONDITIONS IN COMPLIANCE WITH THE SAFETY REGULATIONS.



ALL ABOVE MENTIONED MAINTENANCE INTERVENTIONS MAY BE PERFORMED EXCLUSIVELY BY TECHNICAL COMPETENT AND QUALIFIED TECHNICAL PERSONNEL SATISFYING THE TECHNICAL AND PROFESSIONAL REQUIREMENTS FORESEEN BY THE LAW IN FORCE IN THE COUNTRY OF INSTALLATION.



IN ORDER FOR THE AUTOMATION UNIT TO OPERATE CORRECTLY, WE RECOMMEND CARRYING OUT PERIODICAL MAINTENANCE ON IT, AS INDICATED IN PAR. 7.1 OF THIS MANUAL.



TOPP INFORMS THE USER THAT, IN ACCORDANCE WITH ART. 8 OF MINISTERIAL DECREE NO. 38 OF 22.1.2008, THE OWNER OF THE SYSTEM IS RESPONSIBLE FOR ADOPTING ALL NECESSARY MEASURES TO MAINTAIN THE SAFETY FEATURES SET OUT IN APPLICABLE LEGISLATION, OBSERVING THE INSTRUCTIONS FOR MAINTENANCE AND USE PROVIDED BY THE MANUFACTURER OF THE DEVICE AND BY THE COMPANY THAT CARRIED OUT THE INSTALLATION.

The use of the actuator allows to control automatically the opening and closing of the window according to the type of control device installed (see par. 5.5).

6.2- SMART RESET SYSTEM (SAI)

The Smart Reset System (SAI) is integrated into the software of the electronic control board of **C40S** actuator. This system adjusts the closure of the window in a highly efficient fashion so as not to damage the window in any way. If you were to put an obstacle in the way while the window is closing, the **SAI** would block the actuator(s) attached to the window to avoid damaging it. If this happens in the last 80mm of the movement, that is below the allowable maximum overlap, you might find that the window remains slightly open the next time it is closed. You only need to briefly open and close the window a few times (about 4-5 times) to activate the **SAI** system and restore the window to its correct and proper closure.

7.1- GENERAL INSTRUCTIONS



IF THE ACTUATOR WORKS INCORRECTLY, CONTACT THE MANUFACTURER.



ANY WORK ON THE ACTUATOR (E.G.: POWER CABLE, ETC.) OR ITS COMPONENTS MAY ONLY BE CARRIED OUT BY PERSONNEL QUALIFIED BY THE MANUFACTURER. TOPP DECLINES ALL LIABILITY FOR WORK PERFORMED BY UNAUTHORISED PEOPLE.



EXTRAORDINARY AND ROUTINE MAINTENANCE OPERATIONS INVOLVING THE TOTAL OR PARTIAL DISMOUNTING OF THE ACTUATOR MAY ONLY BE PERFORMED AFTER DISCONNECTING IT FROM THE POWER SUPPLY.

The actuator incorporates components that do not require significant routine or extraordinary maintenance operations.

The recommended maintenance activities should in any case involve the periodical execution (every 6 months) of at least the following operations: that the actuator assembly components are clean, the replacement of components that show signs of superficial damage such as injuries, cracks, discoloration, etc., the fixing systems (brackets and screws) are tight, the window frame is not deformed and the seals are tight, and check the cables and connectors.

The maintenance activity may be carried out either by **TOPP**, in accordance with a specific agreement made with the user, or by the installation technician or by other competent and qualified technical personnel in possession of all legal requirements.

8- DEMOLITION

8.1- GENERAL INSTRUCTIONS



THE DEMOLITION OF THE ACTUATOR MUST OCCUR IN COMPLIANCE WITH THE LAWS IN FORCE ON ENVIRONMENT PROTECTION.



DIFFERENTIATE THE PARTS MAKING UP THE ACTUATOR ACCORDING TO THEIR DIFFERENT MATERIAL TYPE (PLASTIC, ALUMINIUM, ETC.).

9- SPARE PARTS AND ACCESSORIES UPON REQUEST

9.1- GENERAL INSTRUCTIONS



THE USE OF "NON-ORIGINAL" SPARE PARTS AND ACCESSORIES WHICH MAY ENDANGER THE SAFETY AND THE EFFICIENCY OF THE ACTUATOR IS FORBIDDEN.



ORIGINAL SPARE PARTS AND ACCESSORIES HAVE TO BE REQUESTED EXCLUSIVELY TO YOUR DEALER OR TO THE MANUFACTURER STATING TYPE, MODEL, SERIAL NUMBER, AND YEAR OF CONSTRUCTION OF THE ACTUATOR.

Fig. 12

DOME ASSEMBLY BRACKET

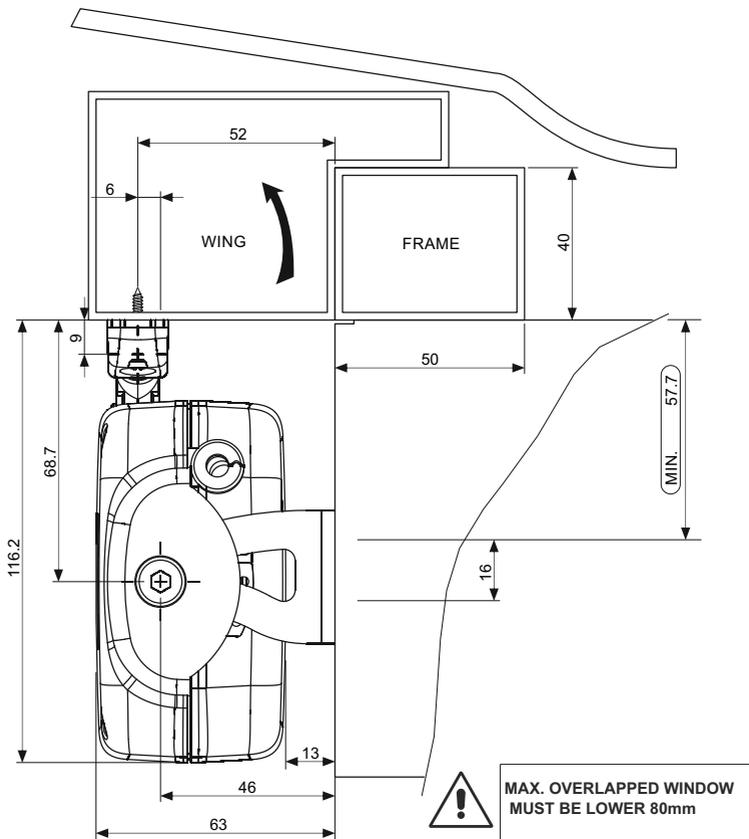

Fig. 13

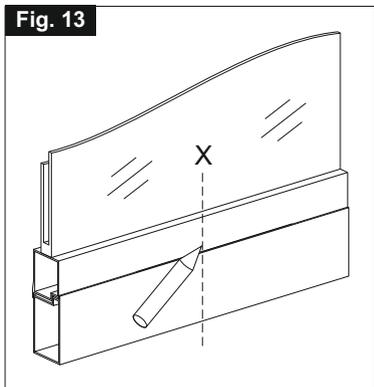

Fig. 14

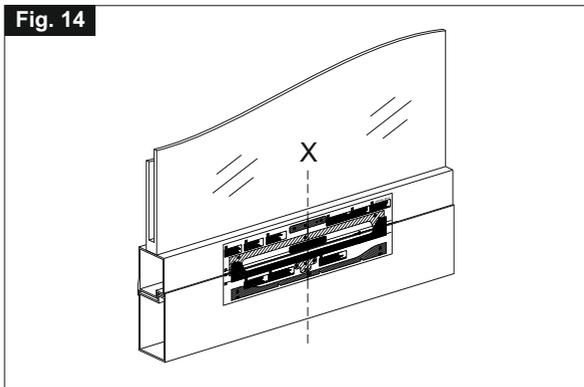

Fig. 15

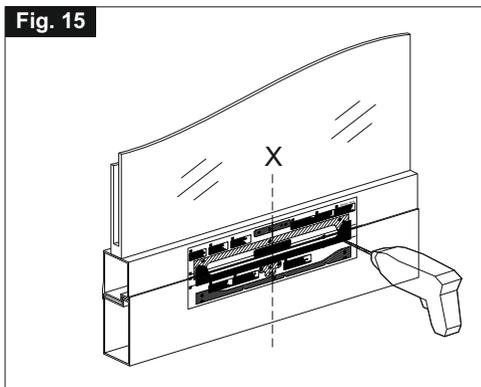

Fig. 16

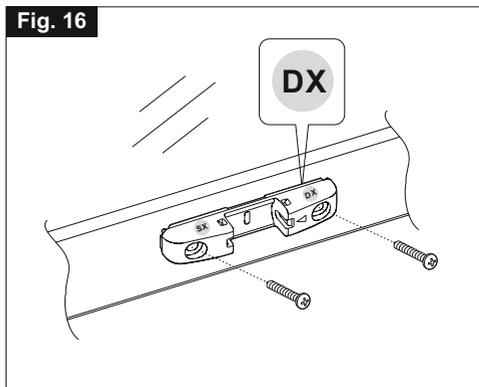

Fig. 17

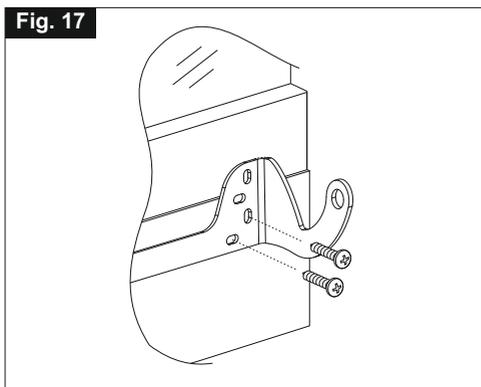
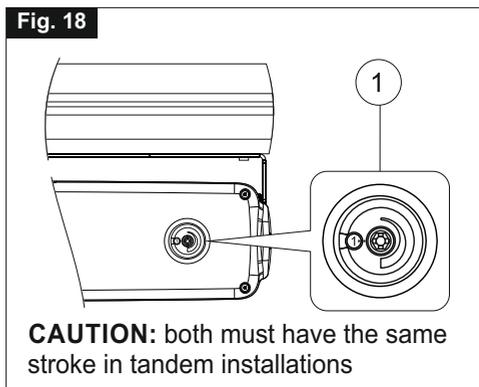

Fig. 18



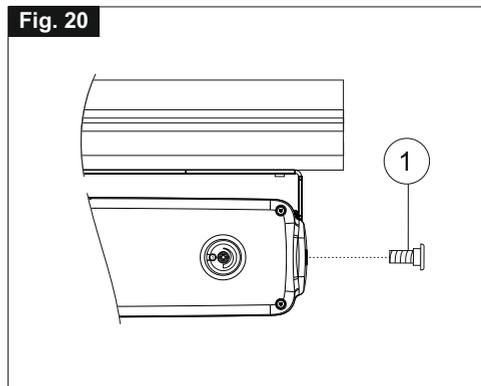
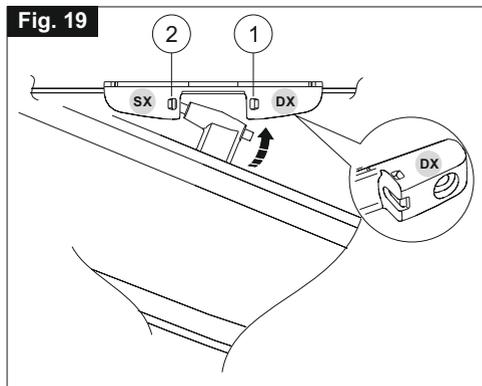

Fig. 21

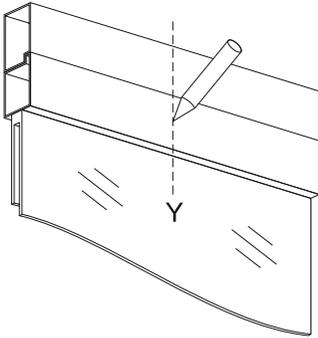

Fig. 22

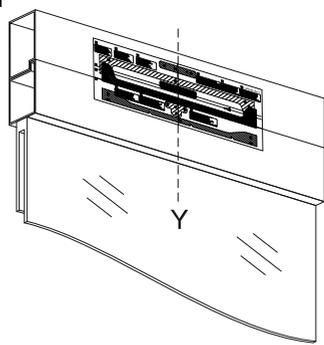

Fig. 23

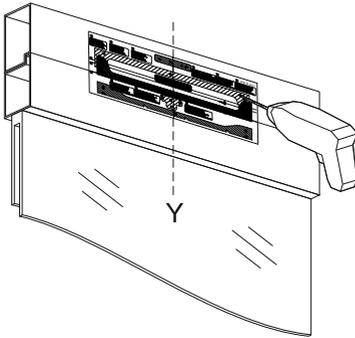

Fig. 24

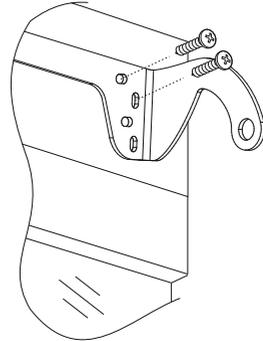

Fig. 25

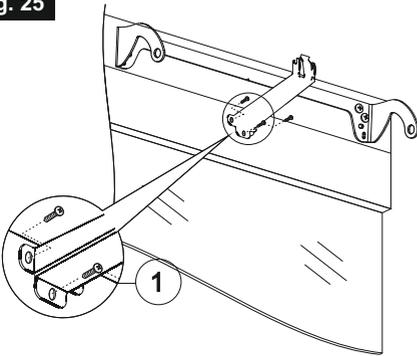
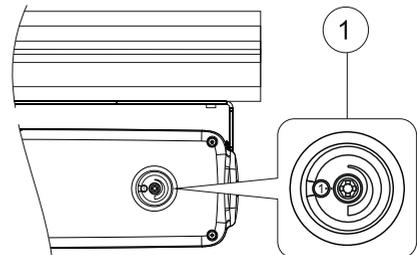

Fig. 26



CAUTION: both must have the same stroke in tandem installations

Fig. 27

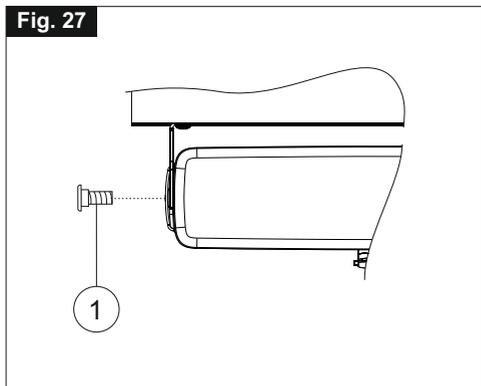
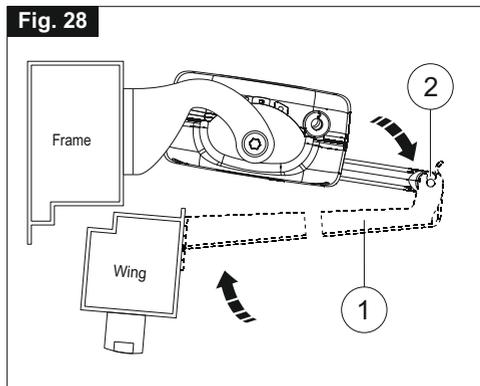
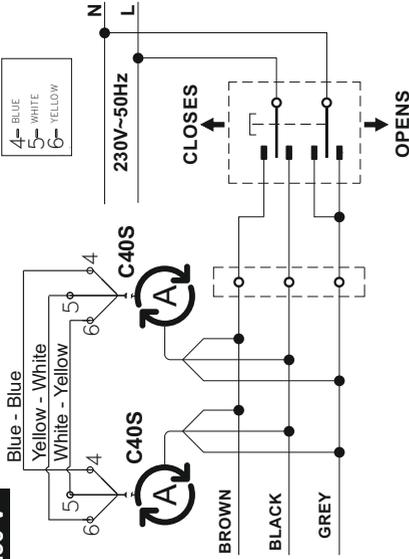

Fig. 28



Wiring diagram

230 V



THIS SYMBOL IDENTIFIES THE TOPP ELECTRICAL ACTUATOR IN WIRING DIAGRAM.

ATTENTION: WHEN USING MORE PUSH POINTS ON THE SAME WINDOW FRAME, DO NOT FEED THEM INDIVIDUALLY.



24 V

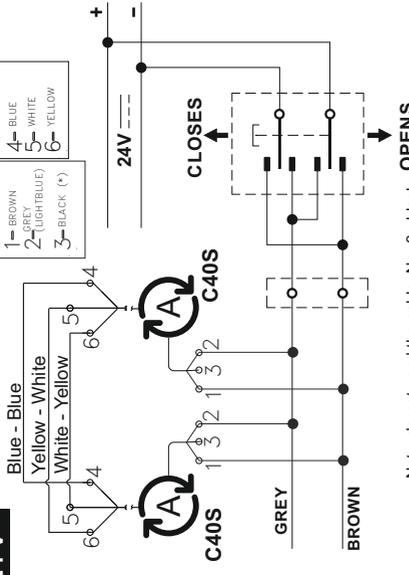

(*) Note: do not use the cable No. 3 - black.

THIS SYMBOL IDENTIFIES THE TOPP ELECTRICAL ACTUATOR IN WIRING DIAGRAM.

ATTENTION: WHEN USING MORE PUSH POINTS ON THE SAME WINDOW FRAME, DO NOT FEED THEM INDIVIDUALLY.

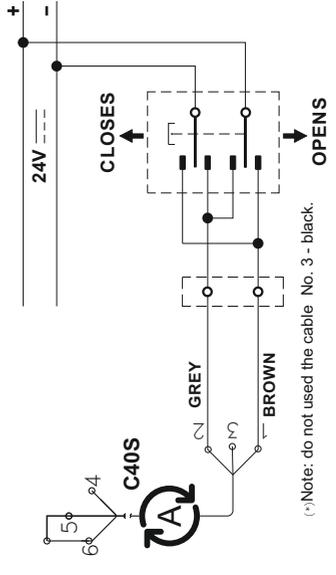

(*) Note: do not use the cable No. 3 - black.

A large grid area for taking notes or recording remarks, consisting of 20 columns and 30 rows of small squares.



TOPP S.r.l.

Società a Socio Unico soggetta a direzione e coordinamento di 2 Plus 3 Holding S.p.a.

Via Galvani, 59 - 36066 Sandrigo (VI) - Italia

Tel. +39 0444 656700 - Fax +39 0444 656701

Info@topp.it - www.topp.it