

KIMO 202

EN

INSTRUCTION MANUAL CHAIN ACTUATOR

Force 200N – Maximum stroke 250 mm
Electrical feeding 24V---



NEKOS S.r.l. - Via Capitoni, 7/5 - 36064 Colceresa (VI) – ITALY

+39 0424 411011 – +39 0424 411013 - www.nekos.it - info@nekos.it

USER INSTRUCTIONS

CAUTION: Carefully observe all the following installation instructions to ensure personal safety.

The device is not intended for use by persons (including children) with reduced physical, sensory or mental capabilities, or lacking experience and knowledge. Do not allow children to play with the fixed controls and keep any remote-control units out of their reach.

Have installation checks performed periodically by qualified personnel from a service centre authorised by the manufacturer. Do not use if repair or adjustment is required.

CAUTION: if the power cable is damaged, it must be replaced by qualified personnel from a service centre authorised by the manufacturer.

CAUTION. Disconnect the power supply during cleaning or maintenance operations. Do not use solvents or jets of water to wash the appliance; the appliance should not be submerged in water.

In the event of fault or malfunction, switch off the device at the main switch. All repairs and adjustments (e.g. setting the stroke) must only be performed by qualified personnel from a service centre authorised by the manufacturer.

Always request exclusive use of original spare parts. Failure to respect this condition could compromise safety and invalidate the benefits contained in the warranty for the appliance. In the event of any problems or queries, consult your agent or contact the manufacturer directly.

The A-weighted sound pressure level is less than 70dB(A).

Carefully preserve these instructions after installation.

INSTALLER INSTRUCTIONS

nekos products have been manufactured in accordance with safety standards and conforms to the stipulations of current standards in force. When correctly assembled, installed and used according to the present instructions, they will not generate any danger for persons, animals or items.

Symbols used in the manual



DANGER

This indication draw the attention about potential dangers for safety and health of peoples and animals.

Contents

1. Security rules.....	4
2. Technical operating information	5
3. Formulas and recommendations for installation.....	5
3.1. Calculation of opening / closure force	5
3.2. Maximum opening based on sash height	6
4. Construction and regulatory references.....	6
5. Id plate and marking data.....	6
6. Technical data	7
7. Electric power supply.....	7
7.1. Selecting the cross-section of the power supply cables.....	8
8. Electrical connection.....	8
9. Instructions for assembly	9
9.1. Preparation for mounting the actuator.....	10
9.2. Recessed mounting	10
9.3. Surface mounting on top-hung windows opening outwards or bottom-hung windows.....	10
10. Programming the actuator.....	11
10.1. KIMO202 programming	11
10.2. RESET Procedure.....	12
10.3. Overlap acquisition.....	12
10.4. LED Light signals	13
11. Checking for correct assembly.....	14
12. Emergency manoeuvres, maintenance or cleaning	15
13. Environmental protection	15
14. Certificate of guarantee.....	15
15. Declaration of incorporation (for a partly completed machine) and EC Declaration of Conformity.....	16

1. Security rules



CAREFULLY OBSERVE ALL THE FOLLOWING INSTALLATION INSTRUCTIONS TO ENSURE PERSONAL SAFETY. IMPROPER INSTALLATION CAN SERIOUSLY ENDANGER SAFETY.



MANDATORY RISK ANALYSIS AND PROTECTION MEASURES.

The Nekos electrical actuators comply with the Machinery Directive (2006/42/EC), Standard IEC 60335-2-103 (Particular requirements for drives for gates, doors and windows) and other directives and regulations indicated in the attached Declarations of Incorporation and CE Conformity (at the end of the manual). According to the Machinery Directive, actuators are “partly completed machinery” intended for incorporation into doors and windows. The manufacturer/supplier of the window is required, with exclusive responsibility, to ensure the compliance of the entire system with the applicable standards and to issue CE certification. We strongly discourage any use of the actuators other than that specified and therefore, in any case, the supplier of the complete system retains full liability.

For systems installed at a height of less than 2.5 m above floor level or other levels accessible to users, the manufacturer/supplier of the window must conduct **risk analysis** regarding potential harm (violent blows, crushing, wounds) caused to people by normal use or possible malfunction or accidental breakage of the automated windows, and to implement suitable protective measures in view of these. Such measures include those recommended by the specified standard:

- controlling the actuators via a “deadman’s button” placed near the system and within the operator’s field of view, to ensure that people are out of the way during operation. The button must be placed at a height of 1.5 m and operated by key if accessible to the public; or:
- use of contact safety systems (also included in the actuators) that ensure a maximum closing force of 400/150/25 N, measured in accordance with paragraph BB.20.107.2 of IEC 60335-2-103; or:
- use of non-contact safety systems (lasers, light grids); or:
- use of fixed safety barriers that prevent access to moving parts.

Automated windows are deemed adequately protected if they:

- are installed at a height of >2.5 m; or:
- have a leading-edge opening of <200 mm and a closing speed of <15 mm/s; or:
- are part of a smoke and heat evacuation system for emergency use only.

In any case, moving parts of windows that could fall below 2.5 m following breakage of a system component need to be fixed or secured in order to prevent them from suddenly falling or collapsing: e.g. the use of safety arms on bottom-hung windows.



The device is not intended for use by persons (including children) with reduced physical, sensory or mental capabilities, or lacking experience and knowledge. Do not allow children to play with the fixed controls and keep any remote-control units out of their reach.

The actuator is destined exclusively for installation indoors. For any special application we recommend you consult the manufacturer beforehand.

After removing packaging, check for any damage on the appliance.

Always request exclusive use of original spare parts. Failure to respect this condition could compromise safety and invalidate the benefits contained in the warranty for the appliance.

In the event of any problems or queries, consult your agent or contact the manufacturer directly.

2. Technical operating information

The chain actuator allows to open and close the window by means of a three-link steel chain (*Nekos Patent*). The movement is achieved with very low-voltage (24V₋₋₋ SELV) electricity that powers a gear motor controlled by a functional electronic device. KIMO 202 actuator is intended for use for room ventilation.

KIMO202 uses the Nekos patented Syncro³ technology which allows to realize synchronised systems till 8 devices without any control unit.

Window opening can be programmed so that the device allows excursion of the chain to strokes of 100 / 170 / 250 mm. Instead for the return stroke (window closure), the stroke-end is determined by an electronic process that automatically calculates the required power absorption to produce the movement of the window, and therefore no settings are required. The actuator, being supplied from factory with the chain in, can be installed even without the immediate availability of electricity for window movement, leaving the window closed after assembly.

The structure of the actuator is in high resistance composite material (Pa6 + 35%GF). The coupling between the actuator and support brackets fixed to the window frame is a quick-connect coupling that allows the actuator to rotate in order to adapt to the stroke of the chain, even on windows with reduced height. The brackets are fixed to the frame during actuator assembly with just two screws. Combined with the **K-LOCK** product and perimeter fittings, it constitutes the security lock that keeps the window closed tight and guarantees a high thermal K.

3. Formulas and recommendations for installation

3.1. Calculation of opening / closure force

Using the formulas on this page, approximate calculations can be made for the force required to open or close the window considering all the factors that determine the calculation.

Symbols used for the calculation

F (Kg) = Force for opening or closing	P (Kg) = Weight of the window (mobile sash only)
C (cm) = Opening stroke (actuator stroke)	H (cm) = Height of the mobile sash

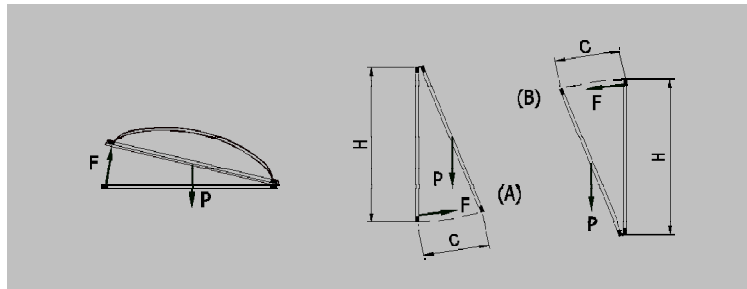

For horizontal light domes or skylights

$$F = 0,54 \times P$$

For vertical windows

- TOP HUNG WINDOWS, OUTWARD OPENING (A)
- BOTTOM HUNG WINDOWS (B)

$$F = 0,54 \times P \times C : H$$

(Possible load exerted by snow or wind on the dormer, should be calculated separately).

(Possible load exerted by favourable or unfavourable wind on the sash should be calculated separately).

3.2. Maximum opening based on sash height

The selection of the actuator stroke should be made based on the height of the sash and its application. As a general rule, never select a stroke greater than the height of the window frame; select the stroke directly below it.

WARNING. If the actuator is recess mounted on the window frame, check that during the stroke the chain does not touch the profile of the sash, there are no obstacles to opening the window and the chain does not push against the window frame.

4. Construction and regulatory references

INTENDED USE The **KIMO202** chain actuator is designed and built to open and close top-hung windows opening outwards, bottom-hung windows or up-and-over roof windows.

Its use is specifically intended for ventilation, air conditioning of rooms and, if used in combination with the K-LOCK window lock, also as a building security system; it is highly recommended that the actuator not be used for any other purpose unless approved by the manufacturer beforehand, with the supplier of the entire system in any case retaining sole liability.

The actuator is manufactured in accordance with the EC Directives and Regulations listed in the attached Declaration of Incorporation and Conformity **CE**. Electrical connections must conform to regulations in force for the design and set up of electrical equipment.



The actuator is individually packaged in a cardboard container and each pack contains:

24V₋₋₋ electrical actuator complete of connector for feeding cable wiring.
Instruction manual

2 brackets for surface mounting



2 brackets for recessed mounting



2 half-brackets for attach to the frame, complete with pin



5. Id plate and marking data

The KIMO202 actuators have CE marking and comply with the Standards listed in the Declaration of Conformity. They also come with a Declaration of Incorporation, due to their classification by the Machinery Directive as "partly completed machines". Both declarations are included in the final pages of this manual.

The plate data is displayed on an adhesive label placed on the outside of the casing, which must remain intact and visible.

The main information it displays includes: manufacturer's address, product name - model number, technical characteristics, production date and serial number.

In the event of a complaint, please indicate the serial number (SN) displayed on the label.

An explanation of the symbols used on the label to abbreviate the technical characteristics is given in the table in the chapter on "TECHNICAL DATA".

6. Technical data

Model	KIMO202 24V _{SELV}
Force exerted by traction (F _N)	200N
Force exerted by thrust (F _N)	120N (250mm), 150N (170mm)
Strokes (S _V)	100, 170, 250 mm
Power supply voltage (U _N)	24 V _{SELV}
Rated absorbed current (I _N)	0,45A
Power absorbed at nominal load (P _N)	10,8W
Electrical insulation	Class III
No load speed	4 mm/s
Duration of no load stroke (250 mm)	63 s
Type of service (D _R)	5 cycles
Operating temperature	- 20 + 70 °C
Protection index for electrical devices	IP42
Adjustment of connection to window frame	Automatic definition of position
Parallel powering of two or more motors	Yes (max 20 actuators)
Coupling with K-LOCK electromechanical lock and AUX accessories	Yes
Synchronised function	Yes (max 8)
Nominal holding force (it can vary according to the chosen brackets)	1000N
Stroke-end at opening	Electronic by dip-switch setting
Stroke-end at closing	At absorption of power
Length of power cable	2 m
Chain exit	Central
Dimensions	21x28,5x354 mm
Weight	0,45 Kg

The data indicated in these figures is not binding and is subject to variation without notification.

7. Electric power supply

The KIMO 202 actuator is powered with a voltage of 24V_{SELV}. The power supply cable has three conductors: the first conductor **RED** that should be connected to the + (positive) CLOSES the window; the second conductor **BLACK** that should be connected to the + (positive) OPENS the window; the third conductor **GREEN** is the conductor used for Syncro³ communication, K-LOCK control communication signal and AUX.

The 24V_{SELV} low-voltage actuators can be powered using a unit with emergency batteries or a security power supply unit, at least in Class 2, with an output voltage of 24V_{SELV} (min. 20.4V_{SELV}, max. 28,8V_{SELV}), that is to say, sized based on the number of actuators connected.

7.1. Selecting the cross-section of the power supply cables

It is necessary to check the cross-section of the cable, which should be calculated based on the length of the cable itself. The table below specifies the maximum length of the cables for connection of a motor.

CABLE SECTION	Actuator fed at 24V _{SELV}
0.50 mmq	~40 m
0.75 mmq	~60 m
1.00 mmq	~80 m
1.50 mmq	~120 m
2.50 mmq	~200 m
4.00 mmq	~320 m
6.00 mmq	~480m

8. Electrical connection

The machines are equipped with a power supply cable constructed in compliance with safety standards and restrictions on radio-frequency interference.

The power supply cable is made in PVC - with conductors having a cross-section of 0.5 mm² - and it's 2 m. long:

- RED-coloured cable (in the drawings marked with "R")
- BLACK-coloured cable (in the drawings marked with "B")
- GREEN-coloured cable (in the drawings marked with "G")

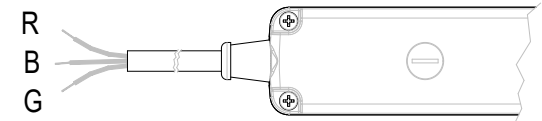

For wiring of a single actuator follow the diagram below:

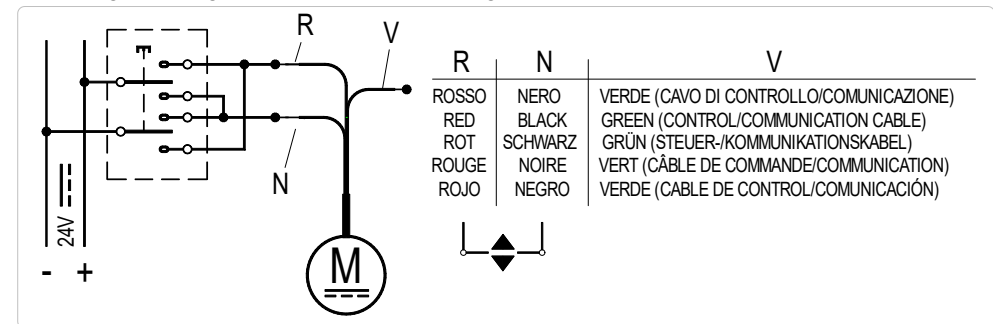

Note: the first conductor **RED** that should be connected to the + (positive) CLOSES the window; the second conductor **BLACK** that should be connected to the + (positive) OPENS the window; the third conductor **GREEN** is the conductor used for the communication signal.

IMPORTANT: when using the actuator in single mode (without any other KIMO202 or K-Lock), GREEN wire must be insulated.

Connection of multiple synchronized KIMO 202 (*Syncro³ Patent*):

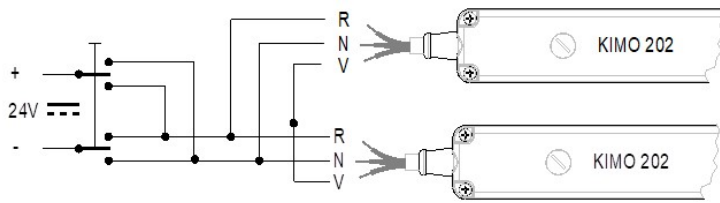

The diagram below shows the wiring when coupling a K-LOCK electromechanical lock.

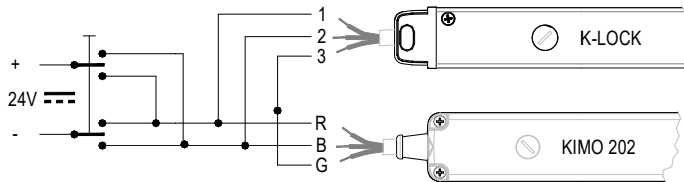

WARNING. Always respect correct electrical connections among the devices; a wrong connection can damage them and generate a dangerous situation.

9. Instructions for assembly

These indications are for specialised technical personnel and basic work and safety techniques are not indicated.

All preparatory, assembly and electrical connection operations must be performed by specialised technical personnel to guarantee optimal function and service of the actuator. Check that the following fundamental conditions have been met:

Before installing the actuator, check that the moving parts of the window on which it is to be installed are in perfect working condition and that they open and close properly and are well balanced (where applicable).

Actuator specifications must be sufficient for movement of the window without encountering any obstacle. The limits indicated in the technical data table must not be superseded (*page 7*) and the most appropriate stroke should be selected. Calculations should be checked using the formula indicated on *page 5*.

Attention. Check that the electrical power supply corresponds to that indicated on the TECHNICAL DATA label on the machine.

Ensure that the actuator has not been damaged during transport, first visually and then by powering in both directions.

Check that the width of the inside of the window (where the actuator is to be assembled) is over 400 mm, otherwise the actuator should not be installed.

Check that once the actuator has been installed, chain completely in, the window is perfectly closed. If this is not the case the actuator will not function correctly as the window will not close correctly.

9.1. Preparation for mounting the actuator

In case of doubts, uncertainties or different applications always contact the manufacturer. For a proper mounting, carefully carry out the following instructions.

Before beginning to mount the actuator, depending on the type of application, the window frame must be prepared by carrying out the following operations.

9.2. Recessed mounting

For recessed mounting, the window frame must be prepared by milling and making four holes as indicated in the diagram below. The depth of the milling must be at least 24 mm.

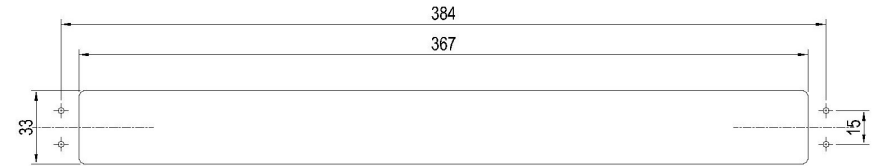

Then make two $\varnothing 4.5$ holes on the sash for the attachment bracket. The measurements are specified in the diagram below.

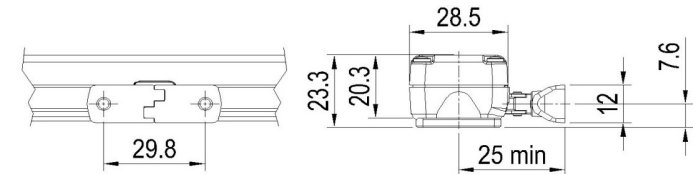

9.3. Surface mounting on top-hung windows opening outwards or bottom-hung windows

The actuator can also be surface mounted on top-hung windows opening outwards or dormer windows and on bottom-hung windows; for this last applications special brackets are required and must be requested separately.

Warning. In order to prevent unpleasant mishaps with the machine and possible safety hazards, carefully choose the length of the clamping screws in order to avoid damaging the power supply cables during the mounting procedure.

In order to carry out a cost-effective and precise up-to-standard work, it is best if you prepare the following complementary material: small parts, equipment and tools.

- ◆ **Fastening on metal window frames:** M4 threaded inserts (*4 pieces for recessed mounting and 4 pieces for surface mounting*), M4x12 flat head metric screws (*4 pieces*).
- ◆ **Fastening on wooden window frames:** $\varnothing 4$ self-threading wood screws (*4 pieces*), with an appropriate length for the type of window frame.
- ◆ **Fastening on PVC window frames:** $\varnothing 3.9 \times 13$ self-threading metal screws (*4 pieces*), with an appropriate length for the type of window frame.
- ◆ **Equipment and tools:** tape-measure, pencil, drill/electric screwdriver, set of drill bits for metal, insert for screwing in, electrician's scissors, screwdrivers.

10. Programming the actuator

10.1. KIMO 202 programming

Closing stroke-end

The closing stroke-end is automatic and non-settable. The position at which the actuator stops is determined by the power absorbed by the actuator when the window reaches complete closure and the seals are completely compressed, i.e., the actuator stops when the power absorbed exceeds a preset threshold.

After each closure or intervention of the electronic protection, the chain moves in the opposite direction for about 1 mm, in order to produce the right compression on the seals and relax the internal mechanical parts. During operation, the KIMO202 actuators automatically recognize and memorize the distance between window sash and frame when the window is completely closed. The difference in the position of the protruding part of the window sash with respect to the frame is defined as the "overlap" and allows the actuator to acquire its own operating parameters, storing the position and type of window frame.

This procedure, known as "OVERLAP ACQUISITION" (paragraph 10.3), occurs the first time the actuator closes the window completely following a RESET operation and remains stored as an operating parameter.

Opening stroke-end

The KIMO202 actuator is supplied with the RESET procedure already executed and a preset maximum stroke. The overlap still needs to be "acquired" (paragraph 10.3), and a smaller stroke selected if necessary.

IMPORTANT. If connecting an electro-lock K-LOCK a new RESET procedure must be carried out.

When using the KIMO202 Syncro³ model, the RESET procedure and acquisition of the overlap must be performed during installation (see paragraphs 10.2 and 10.3) before the desired opening stroke-end can be selected.

We recommend checking the electrical wiring before starting the RESET procedure. If the settings are lost, a new RESET procedure must be performed followed by acquisition of the overlap (see paragraphs 10.2 and 10.3).

Three positions can be selected for the stroke-end positions of the outgoing chain by setting dip switches no. **1** and **2** (see table below). Programming is quick and simple and can be done at any time.

STROKE (mm)	DIP-SWITCH	
	1	2
100	ON	OFF
170	OFF	ON
250	ON	ON

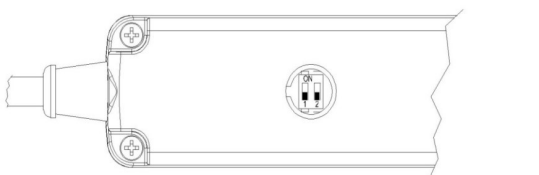

The actuator is factory-set with the longest stroke (250 mm).

10.2. RESET Procedure

This procedure concerns the configuration of a single actuator, Syncro³ setting of or in presence of a K-LOCK electromechanical lock.

This procedure should be carried out with the chain terminal (or terminals, for configurations with several devices) uncoupled from the window sash bracket.

IMPORTANT: The dip-switch settings should be changed to non-powered actuators; after each change it is necessary to wait a few seconds (~ 5 sec) before restoring the power to the actuators in order for the change to become effective.

- Set the dip-switches in the following manner: **DIP 1 OFF – DIP 2 OFF**. For configurations with several devices (or with the K-LOCK electro-lock), the setting of the dip-switches as described above should only be changed for one actuator, and the other devices will link to it automatically.
- Supply power to the actuators (either by opening or closing). The initializing phase will then start.
- The actuator will start at once (or after about 8 seconds if there is an electro-lock) and perform a full closing manoeuvre (chain completely retracted) and then an opening manoeuvre of about 5 cm. During this phase, ensure that there are no obstacles to the movement of the chain and wait until the closing manoeuvre is completed on all actuators.
- When the operation is finished, each connected device gives a flashing orange signal to indicate completion of the RESET procedure. Each device will give a different number of flashes to indicate that the access code is received (actuator 1 → 1 flash → pause → 1 flash → pause; actuator 2 → 2 flashes → pause → 2 flashes → pause, etc.).
- The power supply to the devices can now be switched off and the dip-switches used to set the desired stroke on all the actuators.
- Couple the chain terminal to the movable sash bracket.

Once the RESET procedure is executed, at the next complete closure the actuator will repeat the overlap acquisition operation. If the K-LOCK electro-lock is present, refer to the respective user and installation manual.

10.3. Overlap acquisition

The operation that must be carried out to acquire the overlap (after the RESET procedure has already been executed) is described below:

- Assembly of the actuator(s) on the window (as per chapter 9).
- Electrical connection of the actuator (as per chapter 8).
- Coupling of the chain terminal(s) to the sash bracket.
- Activating the window closing command.
- Wait until the window is completely closed. An orange light will flash on the actuator for 3 seconds to indicate that the overlap has been successfully acquired.

IMPORTANT: If, for any reason, the actuator fails to complete the closure of the window correctly, stopping before finishing the stroke, the RESET and overlap acquisition operation will have to be repeated in that order, until the procedure is completed correctly.

When the window is closed, check that the chain terminal protrudes completely from the actuator body by at least a couple millimetres; this ensures that the window is closed well and the seal is compressed properly, otherwise the window may not be completely closed arising the risk of possible leakages.

Check also that the attachments and support brackets are solidly joined to the window and the screws are tightened properly.

The use of self-threading or self-drilling screws on aluminium windows is not recommended at all, since they can tear the profile after a few manoeuvres; use metric screws with threaded inserts instead (see instructions in paragraph 9.3).

10.4. LED Light signals

If there are any problems during installation or operation of the machines, please take a look to the possible causes listed below:

WITH RED LED		
No. of Flashes	Type of Error	Possible Solution
1	Current error: <i>The actuator has detected an overcurrent in the motor.</i>	Check that there are no obstacles preventing the actuator from completing its stroke. Check that the actuator is installed correctly.
2	Communication error: <i>Communication between the devices is interrupted, or the devices being used have undergone the RESET procedure separately.</i>	Check the condition of the connection cables, and repeat the RESET procedure if necessary.
3	Electro-lock error	Check the electro-lock.
4	Contrasting Dip-switch settings: <i>The devices connected to one another have conflicting Dip-switch settings.</i>	Check the settings of the various Dip-switches.
5	RESET Procedure error: <i>The RESET procedure was not completed successfully or was interrupted.</i>	Repeat the RESET procedure.
6	Wiring error: <i>The power supply cables of the devices configured in Syncro³ modus are inverted.</i>	Check and correct the wiring.
7	Encoder error: <i>The internal encoder had a counting error.</i>	Repeat the RESET procedure.
8	Electric power supply error: <i>The power supply voltage is outside the permitted range or is unstable.</i>	Check the electrical contacts at the ends of the actuator cable and ensure that the power supply is correct.
9	Chain alignment error: <i>The misalignment of the chain</i>	Repeat the RESET procedure.

	<i>terminal positions on devices connected in a Syncro configuration exceeds the maximum amount allowed.</i>	
10	Memory error: <i>The internal memory write process failed.</i>	Repeat the RESET procedure.
11	Connection error: <i>A RESET procedure is being started with actuators different than Syncro³, K-LOCK or AUX</i>	Check the type of actuators chosen for the system. Repeat the RESET procedure.

WITH GREEN LED	
LED Status	Meaning
STEADY-ON	<i>Device powered correctly. The device has correctly performed a chain re- entry stroke, completing the operation by writing the memory; or it is still in motion.</i>
FLASHING	<i>Device powered correctly. The device executed an outgoing stroke of the chain correctly. The number of flashes indicates the number previously assigned to the device during the RESET procedure.</i>

WITH ORANGE LED	
LED Status	Meaning
STEADY-ON Duration < 0.5 sec.	<i>Internal memory write process in progress.</i>
STEADY-ON	<i>RESET Procedure in progress.</i>
STEADY-ON for 3 sec.	<i>Overlap acquisition procedure finished correctly.</i>
FLASHING	<i>RESET Procedure finished correctly. The number of flashes indicates the number assigned to the device in a configuration with several devices.</i>

11. Checking for correct assembly

- Check if the window is perfectly closed at corners and that there are no obstacles caused by incorrect positioning during assembly.
- Check when the window frame is closed if the chain terminal is at least a few millimetres away from the actuator body. This will ensure the window is properly closed and seals are correctly compressed. In the event that this should not be the case there is no guarantee that the window is closed correctly.
- Check if hinges and support brackets are aligned to each other, tightened to the window frame and screws correctly fixed.
- Check if the window reaches the desired position according to the stroke-end selected.
- In the presence of an electro-lock, check if at the end of the actuator closing stroke, the K-LOCK activates and it's closing time is about 4 seconds.

12. Emergency manoeuvres, maintenance or cleaning

In case the window is equipped with flush-mounted actuator and it becomes necessary to open the window manually, due to power failure, mechanism problems, for normal maintenance or external window cleaning, following steps have to be followed:

1. Unscrew the screws which retain the wing to the bracket.
2. Be careful because after taking off screws the bracket (which is in 2 pieces) could fall down.
3. Manually open the window frame.
 **ATTENTION: DANGER** – the window could fall as the sash is no longer held in position by the chain.
4. After maintenance and/or cleaning, repeat points 1 and 2 in reverse order.

13. Environmental protection

All materials used in the manufacture of this appliance are recyclable. We recommend that the device itself, and any accessories, packaging, etc. be sent to a centre for ecological recycling as established from laws in force on recycling.

The device is mainly made from the following materials: aluminium, zinc, iron, plastic of various type, cuprum.

Material dismantle in accordance with disposal regulations.

14. Certificate of guarantee

The manufacturer will guarantee good function of the appliance. The manufacturer shall undertake to replace defective parts due to poor quality materials or manufacturing defects in accordance with article 1490 of the Civil Code. The guarantee covers products and individual parts for **2 years** from the date of purchase. The latter is valid as long as the purchaser possesses proof of purchase and completion of all agreed conditions of payment.

Guarantee of good function of appliances agreed by the manufacturer implies that the latter undertakes to repair or replace free of charge and in the shortest period possible any parts that break while under warranty.

The purchaser is not entitled to any reimbursement for eventual direct or indirect damage or other expenses incurred. Attempt to repair by personnel unauthorised by the manufacture shall render the warranty null and invalid.

The warranty does not cover fragile parts or parts subject to natural wear and tear or corrosion, overload, however temporary etc. The manufacturer will accept no responsibility for eventual damage incurred by erroneous assembly, manoeuvre or insertion, excessive stress or inexpert use.

Repairs performed under guarantee are always "ex factory of the manufacturer". Respective transport expenses (out/back) are the responsibility of the purchaser.

15. DICHIARAZIONE DI INCORPORAZIONE (PER UNA QUASI MACCHINA) e DICHIARAZIONE CE DI CONFORMITÀ / Declaration of incorporation (for a partly completed machine) and EC Declaration of Conformity

Con la presente il / Hereby the

Costruttore: Manufacturer:	Nekos S.r.l. Via Capitoni 7/5 - 36064 COLCERESA - VI - Italy Tel +39 0424 411011 – Email info@nekos.it
-------------------------------	---

dichiara sotto la propria responsabilità che i seguenti prodotti:
declare under its own responsibility that the following products:

Descrizione prodotto : Product Designation:	Attuatore a catena per finestre Window chain drive	
Modello: Type:	230 V : KATO 253 - KATO - KATO 305 KATO SYNCRO³ - KATO 305 SYNCRO³ INKA 356 - INKA 356 SYNCRO³	24 V : KATO 253 - KATO - KIMO - KIMO 202- KATO 305 KATO SYNCRO³ - KATO 305 SYNCRO³ INKA 356 - INKA 356 SYNCRO³

Anno di costruzione dal / Year of manufacturing from: **2019**

Soddisfano gli applicabili requisiti essenziali della Direttiva Macchine 2006/42/EC, Allegato I Fulfil the essential requirements of the Machinery Directive 2006/42/EC, Annex I, Art. 1.1.2, 1.1.3, 1.1.5, 1.2.1,1.2.3, 1.2.6; 1.3.2, 1.3.4, 1.3.9, 1.5.1, 1.5.2, 1.5.6, 1.5.7, 1.5.8, 1.5.9, 1.5.10, 1.5.11, 1.7.1, 1.7.1.1, 1.7.3, 1.7.4.2, 1.7.4.3 La documentazione tecnica pertinente è compilata secondo l' Allegato VII, sezione B The relevant technical documentation is compiled in accordance with Annex VII, Part B

La persona autorizzata a costituire la documentazione tecnica pertinente è:

The person authorised to compile the relevant technical documentation is: **ing. Matteo Stefani – Nekos S.r.l.**

Su richiesta adeguatamente motivata delle autorità nazionali, la documentazione tecnica dei citati prodotti sarà resa disponibile, via e-mail, entro un tempo compatibile con la sua importanza.

In response to a reasoned request by the national authorities, we will provide, via e-mail, the relevant information on the product listed above within an adequate period proportional to its importance.

Inoltre i succitati prodotti sono conformi alle disposizioni pertinenti delle seguenti Direttive:

Furthermore the products listed above complies with the provisions of followings Directives :

- **2014/30/EU Direttiva Compatibilità Elettromagnetica / ElectroMagnetic Compatibility Directive (EMCD)**
- **2014/35/EU Direttiva Bassa Tensione / Low Voltage Directive (LVD)**
- **2011/65/EU Direttiva sulla restrizione dell'uso di determinate sostanze pericolose nelle apparecchiature elettriche ed elettroniche (Direttiva RoHS) / Restriction of the use of certain hazardous substances Directive (RoHS Directive)**
- **2015/863/EU Direttiva Delegata recante modifica dell'allegato II della Direttiva 2011/65/EU del Parlamento Europeo e del Consiglio per quanto riguarda l'elenco delle sostanze con restrizioni d'uso. / Delegated Directive amending Annex II of Directive 2011/65/EU of the European Parliament and of the Council regarding the list of substances with usage restrictions**

e delle seguenti norme armonizzate e/o specifiche tecniche:

and of the following harmonised standards and/or technical specifications:

EN 60335-2-103 ; EN 61000-6-3:2007 + A1:2011 + AC:2012 ; EN IEC 61000-6-2:2019 ; EN 60335-1:2012 + AC:2014 + A11:2014 ; EN 50581:2012
--

La messa in moto di una macchina completa che includa la quasi macchina sopra menzionata, da noi fornita, non è permessa finché non sia accertato che l'installazione sia stata fatta secondo le specifiche e le indicazioni di installazione contenute nel "Manuale d'istruzioni" fornito con la quasi-macchina e che sia stata espletata e documentata, in apposito protocollo, una procedura di accettazione da parte di un tecnico abilitato.

Commissioning of the complete machinery including the above mentioned drives delivered by us is not allowed until it is ascertained that the installation of the complete machinery was performed in accordance with the specifications and the operating and installation advice given in our Mounting Instructions, and that the acceptance procedure was duly carried out and documented in an acceptance protocol by a specialist.

Questa dichiarazione è fatta dal costruttore / This is declared by the manufacturer:

NEKOS SRL - Via Capitoni 7/5 - 36064 Colceresa - VI - Italy

Rappresentato da / Represented by:

Giuliano Galliazzo – A.D. Presidente / President CEO

Luogo e data / Place and date: Colceresa **05/06/2020**

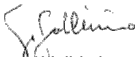
Firma / Valid signature